

OPERATING INSTRUCTIONS

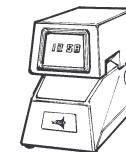

Automatic Number, Date, & Time Stamp

Automatic Date Stamps & Validators

Automatic Seal Embossing Stamps

Automatic Number Stamps

Automatic Time Stamps

Automatic Stamps

Check Certifiers

Check Signers



WIDMER

TIME RECORDER CO., INC.

Since 1933

Widmer Time Recorder Co, Inc.

Hackensack, New Jersey 07601

United States of America

Tel: 201 489-3810

Fax: 201 489-3478

Website: www.widmer.com

E-mail: widmer@widmertime.com

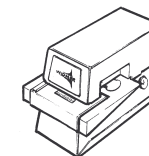

Widmer Stamp Specifications

OPERATING INSTRUCTIONS FOR WIDMER AUTOMATIC RECORDERS

MODEL SERIES: T, TLED, E, D, N, ND, DN, CC, O, R, S, R-3S & 776

Please record the serial number, model number and key number for future reference.

Serial _____
 Model _____
 Key # _____

Basic Models	Voltage	HZ	Amp	Dimensions	Weight
T, TLED, E, D, N, ND, DN, CC, O, R, S, R-3S	110 (or) 220/240	60 (or) 50	0.025	Height 7 3/8" (18.7cm) Width 4 9/16" (11.6cm) Depth 10" (25.4cm)	14 lbs. (6.35kg)

Definition of symbols found in this manual or on the equipment itself.

 WARNING = Improper handling may cause bodily accidents including serious injury and death.

 CAUTION = Improper handling may cause material or bodily harm.

 ELECTRIC SHOCK = Hazard if improperly handled.

 = PROTECTIVE EARTH GROUND

(N) = NEUTRAL TERMINAL ON CIRCUIT BOARD

Double Width Casting

776(N)&(D) , 776-LED, 776E	110 (or) 220/240	60 (or) 50	0.025	Height 7 3/8" (18.7cm) Width 7 1/4" (18.4cm) Depth 10" (25.4cm)	30 lbs. (13.61kg)
-------------------------------	---------------------	---------------	-------	---	----------------------

WARNINGS & CAUTIONS

To change the ribbon—on models 776 D & 776 N. Please note this ribbon is different from other models. The 776 uses a double ribbon and the spool has consecutive circles which should always be on the left side of the machine next to the ribbon transport levers. To change this ribbon, grasp the ribbon in the center front "C" on the double spool area. Lift ribbon feeler "A" and push the ribbon sideways to the right side against the spring clips. Repeat the procedure for the rear spools. To install a new ribbon, reverse the procedure. (fig. 7)

 **WARNING:** Never attempt to re-link ribbons. This will clog the wheel and cause a failure of the machines operation.

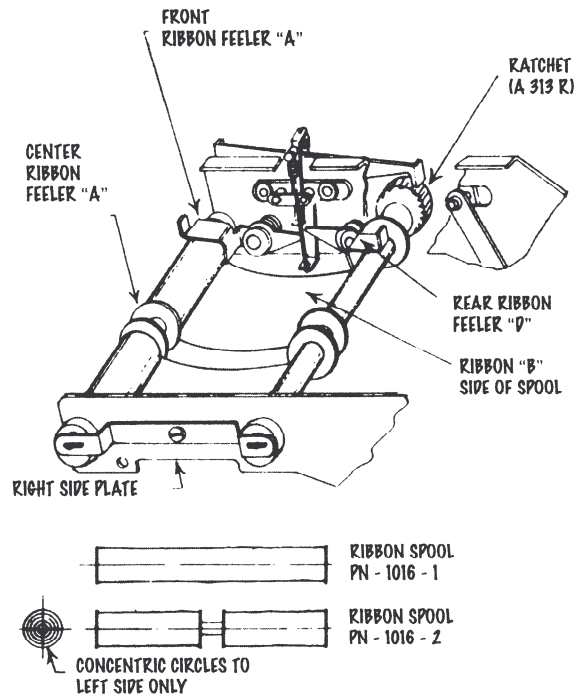







Figure 7

 **WARNING** If a new unit appears damaged due to shipping or appears to have water damage, do not plug it in. Likewise if an existing unit appears abused, unplug it and call for authorized service .

 **WARNING** Never operate the unit in a wet or damp location.

 **WARNING** Please check the current voltage and cycles on the specification plate at the rear of the machine. Make certain that these conform with the power sources that you intend using. Use of improper power will damage the unit, void it's warranty, cause as unsafe condition and possible fire or electric shock.

 **WARNING** Always locate the unit near an easily accessible electric outlet-socket.

 **CAUTION** These units are constructed of rugged metal parts and housed in cast metal cases, 14lbs (6.35kg) to 30 lbs. (13.61 kg). They must be placed on a sturdy surface to operate.

 **CAUTION** Never Stamp the unit with case unlocked.

 **CAUTION** Do not insert extra thick documents as this will cause the machine to malfunction. If jamming occurs, disconnect the plug from the receptical, remove the thick document, then reconnect the plug.

 **CAUTION** Remember to unplug the machine whenever you are working on it.

TO OBTAIN AN IMPRINT— Close and lock the case and insert the plug in the proper grounded receptical. Place the paper in the slot between the upper and lower castings; the document will trigger the automatic stamping mechanism.

LUBRICATION AND MAINTENANCE— Machines are fully lubricated when leaving the factory. They will only need a drop or two of high-grade business machine oil about once or twice a year on all moving parts. Do not get oil on the ribbon, or non-metal or electrical parts. Do not oil excessively as this could clog the mechanism. A good clear imprint can be maintained by occasionally cleaning the type wheels and dies with a typewriter brush or rag; do not use cleaning fluids. The case can be cleaned by wiping with a mild detergent and water occasionally.

TO SET THE PRINT WHEELS:

TIME STAMP—Insert case key in lock and rotate key towards you. Lift up the top of the machine and set the wheels by using a wooden stylus or pencil to rotate the wheels in a downward direction; setting each wheel to the time and date you desire. Please be sure that the A-P wheel is set correctly or else the date will change at 12 noon instead of 12 midnight. At the first of each month please reset the date and month wheels and on the first day of the new year, reset the year wheel. (fig. 1)

NUMBERING MACHINES— Rotate the wheels downward and always set the number to 1 digit lower than the number that you wish to print. For example: to print the number 000001, set the machine to 000000. Only the first six digits of any numbering machine work automatically. Additional prefix of suffix wheels and date wheels must be manually set.

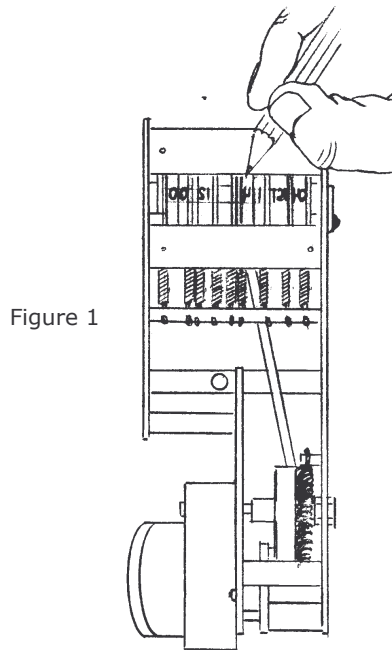



Figure 1

TO CHANGE THE RIBBON— On all models T, TLED, E, D, N, ND, DN, CC, O, R, S, R-3S, & 776E lift ribbon feeler A and slide ribbon B off shaft. Accomplish this on both the front rear ribbon feelers. Replace with the Model 1000 ribbon, being sure to place the spools under the ribbon feeler. (fig. 6)

 **WARNING:** Never attempt to re-ink ribbons. This will clog the wheel and cause a failure of the machines operation.

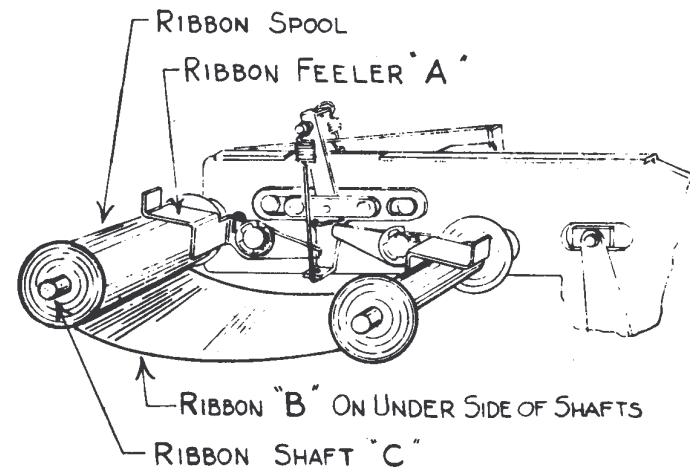
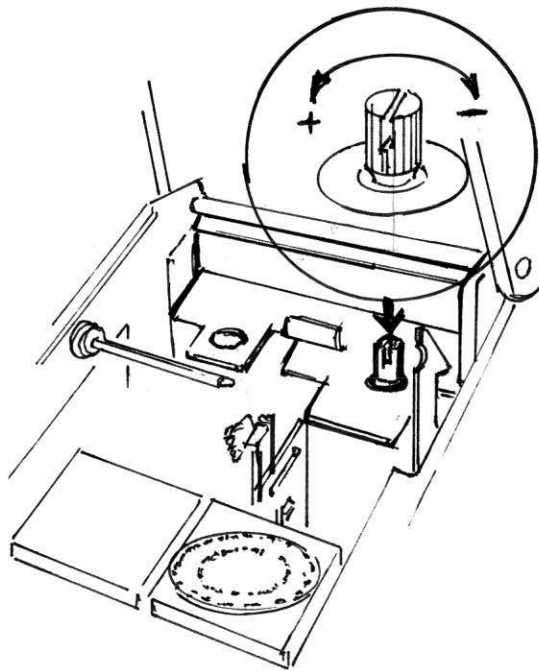

Figure 6

Electric Seal Embosser Models E & 776E

The Model E-3 will produce a raised image on a document. For security purposes this makes a document difficult to forge or duplicate. The model 776E combines the raised seal with text, date, time or consecutive numbers printed through a multicolor ribbon in one operation. Both models have a user friendly adjustment knob to increase/decrease the seal stamping pressure to accommodate the thickness of the form. (fig. 5)



MODEL CC; CHECK CERTIFIER- The model CC Check Certifier is set the same as the numbering machines Model N and Model ND. Please see those instructions.

TO SET THE LED DIGITAL CLOCK FACE:

Please Note: If you purchase a unit with the LED digital clock face accessory, the display has been improved to provide larger characters and a simplified way to synchronize the display with the print wheels.

Unlock and open the top cover of the Stamp. Next locate the three clock face setting buttons in front of the print wheels and behind the clock face. The buttons reading from left to right are: Hour set, Minute set and Hold. (Fig. 2)

Using the hour set button, advance the display to the correct hour. Then use the minute button to advance the time to the same minute that you have set on the print wheel. If you wish to synchronize the digital display with the print wheels, proceed as follows: Using the minute set button, advance the time to 1 minute beyond the time set on the print wheels. For example, if the print wheels are set at 12:00 P.M., the time display would be advanced to 12:01. To synchronize the face with the print wheels, depress the hold button and continue to hold it in until you hear the click of the print wheels changing. When you hear this click immediately release the hold button. Your LED is now synchronized with the print wheels.

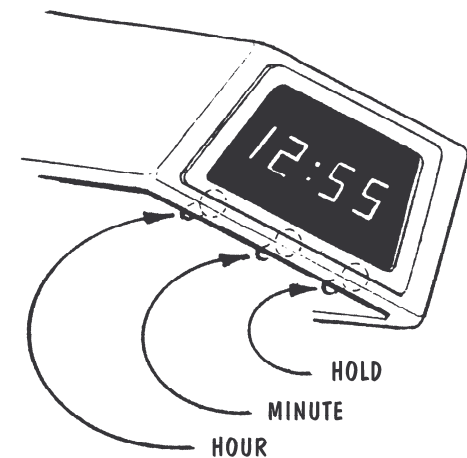

DATE STAMPS- Date stamps are set the same way as the time stamps, only on a daily basis. The date wheels do not advance automatically on any of these models. (fig. 3)

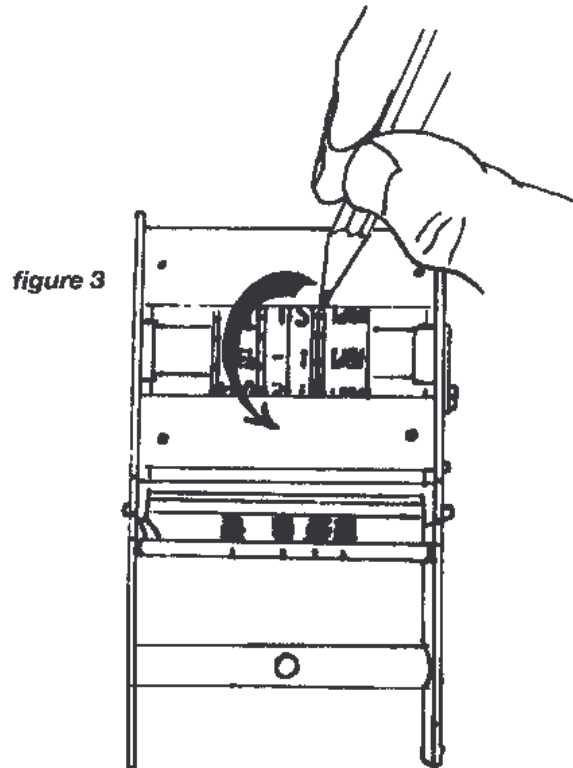

figure 3

AUTOMATIC STAMPS; MODELS O & R- These machines are not furnished with wheels. The model O imprints fixed die information only. The die is screwed into the machine. The model R prints fixed die information. As well, however, the die can be removed by depressing a lever located below the engraved die plates on the machine. Depressing this lever will release spring clips which will allow you to remove the die plate and substitute another die.

AUTOMATIC CHECKSINGER MODELS S & R-3S. These models are equipped with unique keys for the case lock and electric security lock. Please make sure you record the numbers of both the case lock and the security lock (if applicable). The security counter on the Model S is a non-resettable counter. Please log the number at the start and completion of each check run and verify the number of checks that have been stamped by the machine. The die plate can be easily removed by inserting the case key, rotating the key forward towards you and lifting the top of the case. Below the upper frame assembly is a release lever marked "Push Lever". (fig. 4) When inserting or removing the signature, grasp the die plate holder by the convenient handle, depress and hold the release lever and slide the plate along the dove tail in the direction indicated

The model R-3S is identical to the models S. However, it lacks some of the security features such as the visual counter and security lock. Both models are also equipped with an adjustable guide shelf. This shelf can be moved left or right to accommodate your check by simply loosening the knob on the front of the machine and sliding the shelf to the proper location for your check. In most cases, the shelf is preset for your check when shipped from the factory. If your forms are not accommodated by the standard guide, custom built shelves are available, either fixed or adjustable, on special quotation.

The adjustable guide in conjunction with a square signature plate can be mounted to the holder in any of four directions. This will allow you to accommodate most checks

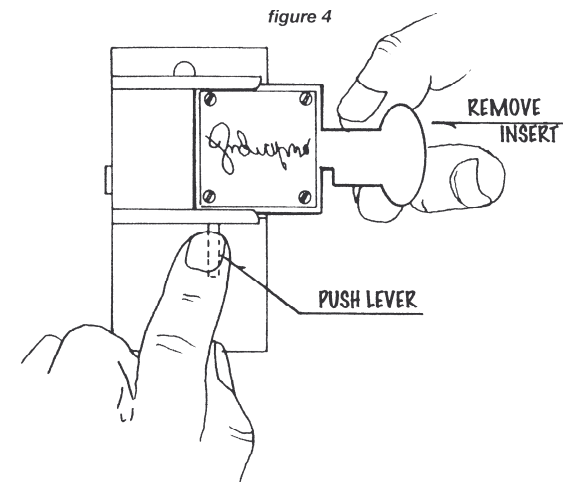

figure 4